

650x650x20U Street Cabinet

Designed to meet the requirements of customers requiring an exterior cabinet capable of mounting deeper 19" equipment, with facilities for mounting electrical metering and power distribution equipment and backup batteries.

Cabinet measures 676x650x1320mm (WDH) and is equipped with doors front and rear for best possible access. The doors open 180° and are hinged from the same side, allowing the unit to be mounted side on to walls or adjacent to each other without impeding cabinet access.

19" mountings accommodate up to 20U of equipment and will accept 400mm long slide rails, offering approximately 100mm in front of the frame and 500mm behind. The frame is offset towards the lock side to allow space for electrical supply meters and fuse boxes to be mounted on the hinged side for which a wooden board is supplied. Cable management is provided along the frame edge.

Three extraction fans with thermostat controlled fans are located in the roof.

Space is available in the lower section of the cabinet for UPS batteries and is access via a removable shelf.

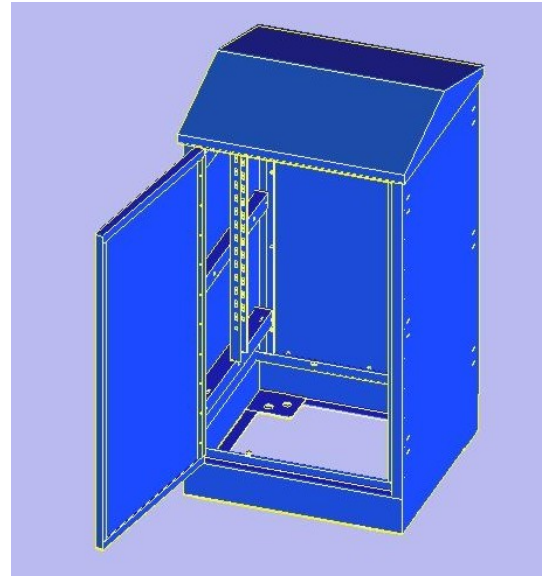

Features

Size: (WHD)	675x1320x650
19" Frame	20U
Internal Space	580x1010x580
Materials:	Chrome Steel
Ventilation	Forced extraction 3 thermostat controlled fans, vermin proof lower vents
Weather Rating:	IP55
Other	Earth bonding Document wallet front and rear Mounting board for electrical equipment (approx size 150x650mm with 140mm depth) Integral Cable Management

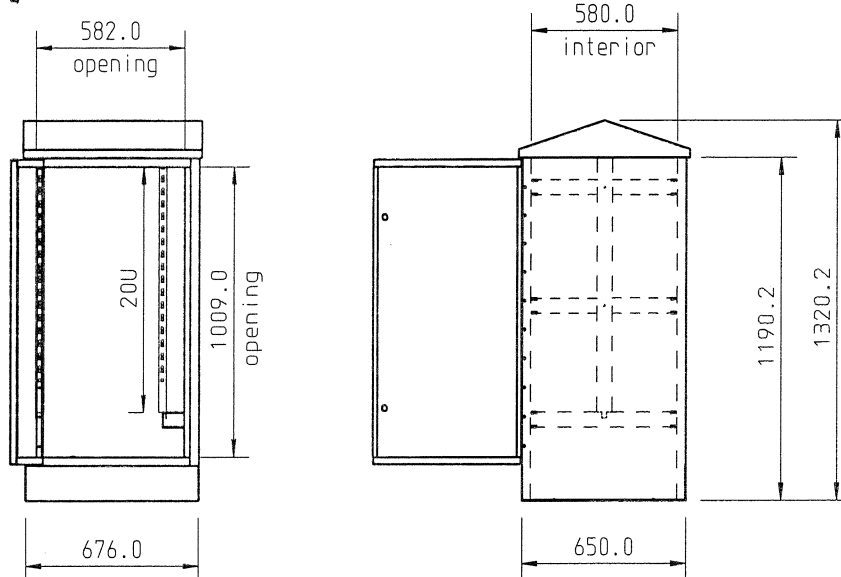
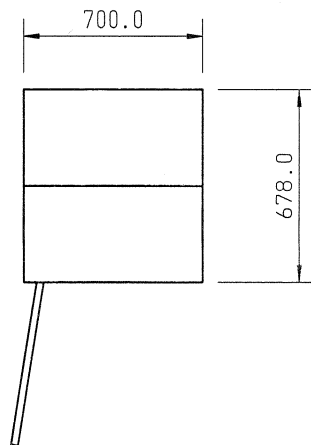

Austin Taylor Communications Ltd
Bethesda, Gwynedd, LL57 3BX, UK

A subsidiary of
Communications Systems Inc.

UK Tel: 01248 602555
UK Fax: 01248 600370

Int. Tel: +44 1248 602555
Int. Fax: +44 1248 600370

<http://www.austin-taylor.co.uk>



BS EN ISO 9001
Reg No: Q 5117